

HEATRAE SADIA

The quality name in water heating

Unvented water heating

Megaflo HE | Megaflo HE SystemFit



Megaflo HE UNVENTED WATER HEATING

Nothing quite matches the warm welcome offered to you by the outstanding range of unvented water heating systems from Heatrae Sadia.

Megaflo HE units are designed and manufactured to a very high quality using the latest manufacturing techniques. They boast numerous innovative features designed to ensure high levels of operating efficiency.

High performance 'coil in coil' heat exchanger

Exceeds CHeSS* Best Practice for recovery times and insulation

Improved insulation for maximum heat retention

New water inlet controls increase flow rates by up to 35%

Improved performance at low pressures down to 1 bar

Installer friendly design

In addition to the advantages of unvented systems Megaflo HE offers a number of features that place it well ahead of the competition in terms of performance, quality and reliability.

So, whether it's for the home environment, the workplace or demanding applications such as sports and health club shower rooms, there's a model to suit your needs.

Powerful mains pressure showering

Faster filling baths

Constructed in Duplex stainless steel for maximum strength - pressure tested to 15 bar

Patented internal floating baffle system to accommodate water expansion

No anode - eliminates costly anode maintenance

CFC/HCFC-free (ODP zero) foam injected insulation for maximum heat retention

Insulated casing for the temperature and pressure relief valve to minimise heat loss

Unique 'L-shaped' long-life Superloy immersion heater reaches deeper into the tank giving more hot water

Smart and attractive appliance-like finish designed with the home owner in mind

Patented cold water inlet diffuser minimises mixing of cold and hot water

25 year transferable cylinder guarantee**



NEW FOR 2008

Reduced heat loss with the introduction of Megaflo's innovative insulated casing for its temperature and pressure relief valve.

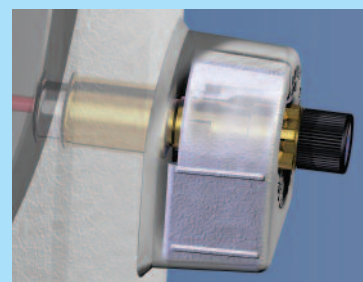

Even more installer friendly Megaflo HE is now supplied with a wiring centre (indirect models only) and drain valve.



* Energy Efficiency Partnership: Central Heating System Specifications. **Guarantee applies to UK installations only.

Megaflo HE UNVENTED WATER HEATING

Duplex stainless steel offers a superior resistance to corrosion especially in aggressive water areas, compared with copper, glass-lined steel and some grades of stainless steel. Because Duplex is a low carbon, high chromium content alloy, it resists all forms of corrosion including pitting, crevice corrosion, uniform corrosion and stress corrosion cracking, without the use of a sacrificial anode. In addition, the tungsten inert gas welding coupled with the special post weld processes ensures the same level of corrosion resistance and mechanical strength as the parent metal. This ensures the longest possible working life for every cylinder.

The combination of its lightweight and very strong construction makes Megaflo HE easier to handle on site. Every unit is pressure tested in the factory to 15 bar - five times the normal operating pressure - making Megaflo HE suitable for all domestic and commercial applications.

No sacrificial anode is required with Megaflo HE. With inferior grades of stainless steel, glass lined steel and copper, sacrificial anodes are required to achieve a degree of corrosion resistance. However they require regular replacement which, if not carried out can result in premature cylinder failure. Megaflo HE overcomes any need for this by using top quality Duplex stainless steel.

Specification comparison to a copper unit with air gap		
	Megaflo	Copper
Maximum working pressure	10.0 bar	4.5 bar*
Operating pressure	3.0 bar	2.1 bar*
Material	Duplex Stainless Steel	Copper

Internal expansion system with Megaflo HE. Expanded water is accommodated within the cylinder using an internal air gap maintained by a patented floating baffle.

This baffle floats on the surface of the water within the cylinder to maintain the integrity of the air gap.

The internal air gap and floating baffle system allows for a compact self contained unit which eliminates the need for an external expansion vessel and allows for a quicker and simplified installation.

Megaflo HE meets the BBA internal expansion volume endurance test with no reduction in operating pressure or flow rates.

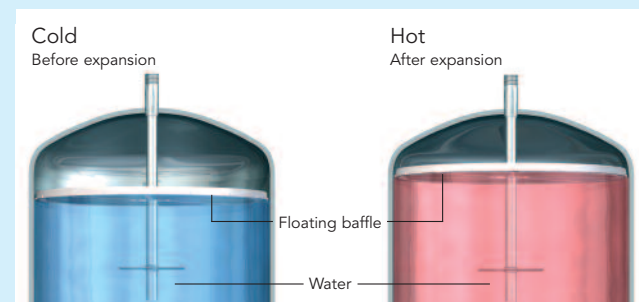

Thanks to the new high performance 'coil in coil' heat exchanger, hot water is available quicker and more efficiently than ever before.

High output ratings 15.4kW to 24.5kW

More efficient transfer of energy

Fast heat recovery

Positioned low in the cylinder to achieve more usable hot water

Promotes boiler efficiency
 - especially condensing types
 - significantly reduces cycling time

The patented cold water inlet diffuser reduces turbulence to minimise the mixing of cold and hot water.

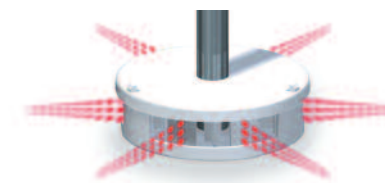

- ▲ Cold water inlet diffuser
- Coil in coil heat exchanger ▶
- Temperature and pressure relief valve insulation ▼

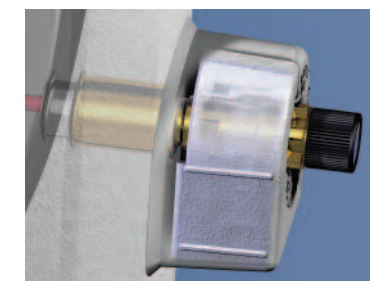

Minimal heat loss A 50mm thick void-free layer of high-performance polyurethane foam fills the space between the inner vessel and outer casing for maximum insulation efficiency.

Megaflo HE's carefully moulded one-piece insulation cannot separate in transit to ensure that its effectiveness is maintained, unlike other designs, which rely on the butt jointing of sheet materials.

Megaflo HE is supplied with an innovative casing which insulates the temperature and pressure relief valve.

The base is fully insulated and the unit stands on three moulded feet to minimise heat losses to the supporting floor. Immersion heaters and controls are fully integrated - no large external bosses to radiate heat.

Megaflo HE is guaranteed a long operational life and with no anode to inspect or replace maintenance costs are reduced.

All Megaflo HE units are backed by our 25-year transferable on-site service support cylinder guarantee as part of Heatrae Sadia's 'fit and forget' product programme.



*Source WRC July 1992

Installer friendly design

New Megaflo HE has been designed to facilitate a trouble-free installation.

Compact and rounded in design, with all connections accessible at the front of the unit. Megaflo HE's lightweight construction means it's easy to handle and convenient to site almost anywhere in the home.

Integral cylinder wiring centre for controls

Strong feet for additional stability

Wiring centre for indirect controls supplied loose with every indirect Megaflo HE (factory fitted to SystemFit models)

All plumbing connections are colour coded and accessible at the front of the cylinder

Lightweight construction

Drain valve supplied loose with every Megaflo HE (factory fitted to SystemFit models)

Megaflo HE base moulding with integral hand grips

Detachable lifting handle



Megaflo HE is supplied complete with:

3/4" BSP threaded connections and 22mm compression nuts and olives

HiFlo cold water valve set complete with integral isolating valve

- Increased flow rates by up to 35%

- Improved performance at low pressures down to 1 bar

15mm x 22mm tundish

Factory fitted 15mm Temperature and Pressure Relief Valve (insulation casing supplied loose)

Expansion relief valve - 8 bar factory setting

Pressure reducing valve - 3 bar factory setting

2 port motorised valve (indirect models only)

Drain valve

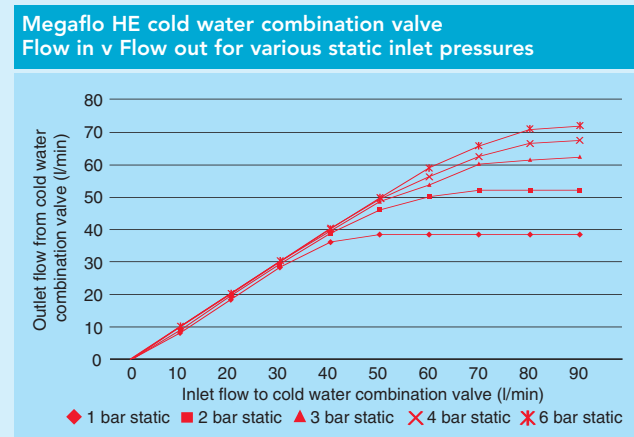
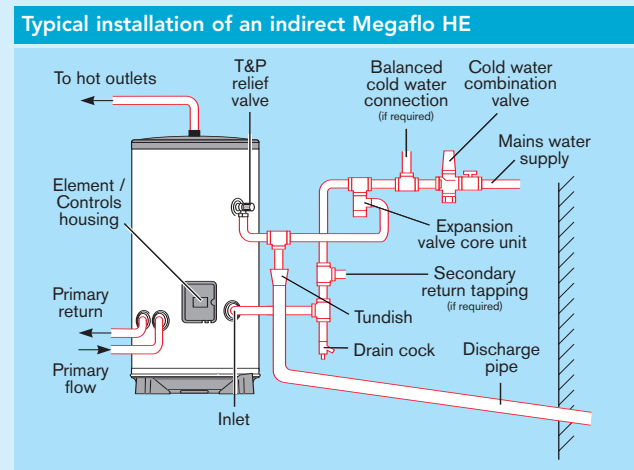

Installer training Approved courses are available nationwide for operative training. For further details of such courses, call 0845 600 7402.

Performance and specification Whether you're at home, at work or at your local sports centre, it's good to know that when it's needed Megaflo HE is more than capable of meeting your requirements.

Megaflo HE's pressure and flow rate performance will exceed those available from comparable vented systems, thermal store units, multi-point instantaneous gas heaters or combination boilers. It offers flexibility in cylinder siting as it can be positioned in any convenient location that allows a suitable routing of the discharge pipe from its safety valve. It should not be installed in areas that are subject to freezing.

Megaflo HE unvented water systems deliver hot water at flow rates up to 72 litres/min and offer one of the most rapid heat-up and recovery rates available, making it ideally suited to a wide variety of applications. Available in seven capacities, ranging from 70 to 300 litres, in both direct and indirect systems, there is a model to suit every environment.



Whatever the need, Megaflo HE is the natural choice. From starter homes through to commercial and light industrial users, Megaflo HE is the perfect solution.

Which unit to use		
Application	Indirect	Direct
Bedsit	CL70HE	D70HE
1 bed 1 bath & shower	CL125HE	DD125/DD145HE
2 bed 1 bath & shower	CL125HE	DD145/DD170HE
3 bed 1 bath & shower	CL145HE	DD210HE
4 bed 1 bath & shower	CL170HE	DD210HE
4/5 bed 2 bath & shower	CL210HE	DD250HE
4/5 bed 3 bath & shower	CL250HE	DD300HE
Light commercial usage†	CL250HE	DDD250/DDD300HE
Other commercial uses†	CL300HE	DDD250/DDD300HE

Figures are for guidance only and are based on BS 6700 recommendations.

- D = One element
- DD = Two elements
- DDD† = Three elements
- CL = Indirect with one element supplied

For additional immersion heater with thermostat, please order: Upper 'straight' 95:970:510††

Note: Heatrae Sadia's Specification Advice team should be contacted to discuss requirements and designs for specific sites.

Element loading options			
Model		Bottom	Top
D	1 x 3kW	1	n/a
DD	2 x 3kW	1	1
DDD	3 x 3kW	2	1
DDD*	4 x 3kW	3	1
CL	1 x 3kW	1	n/a
CL††	2 x 3kW	1	1

High usage applications When it comes to meeting the needs of demanding applications, e.g. rugby club shower rooms, two or more Megaflo HE units can be installed in parallel.

Detailed specifications and designs, including comprehensive plumbing information, are available by contacting our Specifier Advice Team on Tel: 01603 420220 or by Fax: 01603 420229.

Examples of installations using Megaflo HE units in parallel		
Application	Indirect	Direct
Nursing home (27 beds)		3 x DDD250HE
Student accommodation (18 showers)	2 x CL300HE	
Sports club (13 showers)	6 x CL210HE (2 x 3)	
Rugby club (max. 80 showers per hour)		6 x DDD300HE (2 x 3)
House (5 bed + 5 bath)	2 x CL250HE	
Bar with food servery (300 persons)	3 x CL300HE	
Hotel (8 bed + 6 bath)	2 x CL300HE	
Guest house (4 baths + 3 showers)	3 x CL145HE	



† Illustration showing two Megaflo HE units in parallel for high usage applications. Photograph for illustrative purposes only - bespoke pipework required for specific applications.

† DDD cylinders are supplied with three elements and a blanking plug which can be fitted as required to 4 bosses, one at the boost position and three near the base of the unit. This gives a choice of heating options dependent on application. CL210HE, CL250HE and CL300HE have boost upper element boss blanked off.
 †† additional element option on CL210HE, CL250HE, CL300HE and DDD models only.
 * When fitted with additional immersion heater 95:970:510.

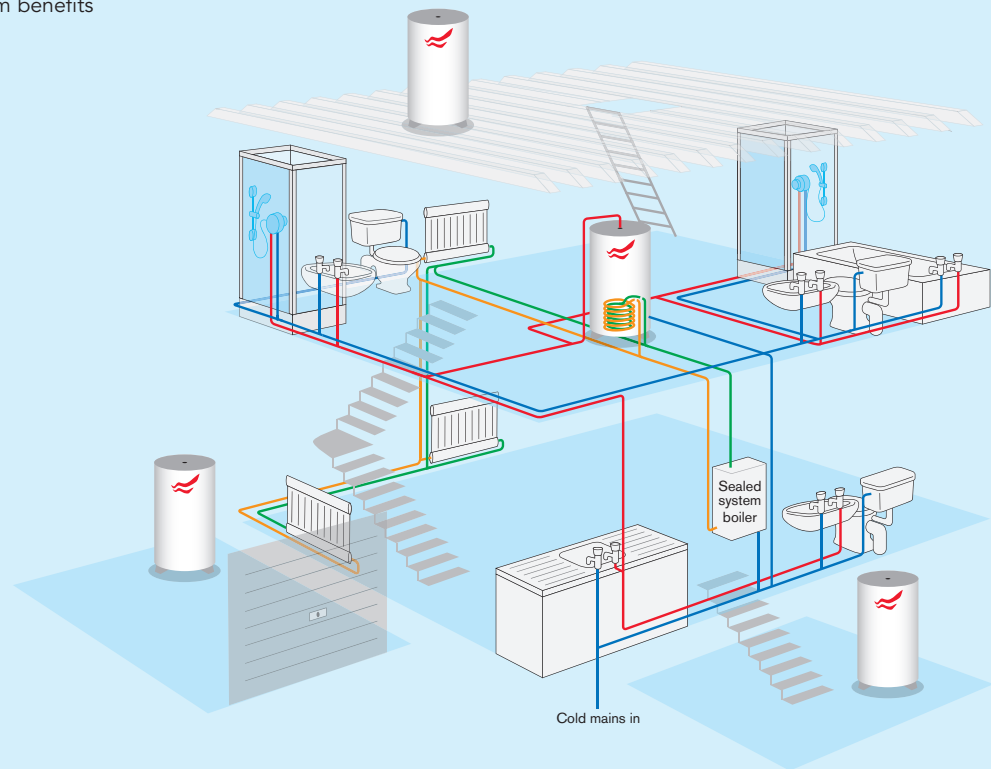

KEY

- Flow } Central Heating System
- Return } Central Heating System
- Hot } Domestic Water System
- Cold } Domestic Water System

Megaflo HE system benefits			
End User	Specifier/ Developer	Installer	
<input type="checkbox"/>	<input type="checkbox"/>	<input type="checkbox"/>	Higher flow rates for efficient hot water delivery
<input type="checkbox"/>	<input type="checkbox"/>	<input type="checkbox"/>	High performance showering - throughout the home
<input type="checkbox"/>	<input type="checkbox"/>	<input type="checkbox"/>	Fast-filling baths
<input type="checkbox"/>	<input type="checkbox"/>	<input type="checkbox"/>	Quieter mains pressure system (no noisy cistern in the loft)
<input type="checkbox"/>	<input type="checkbox"/>	<input type="checkbox"/>	Balanced water pressure - no surprises
<input type="checkbox"/>	<input type="checkbox"/>	<input type="checkbox"/>	Patented cold water inlet diffuser minimises mixing of cold and hot water
<input type="checkbox"/>	<input type="checkbox"/>	<input type="checkbox"/>	Exceeds CHES* Best Practice for heat recovery
<input type="checkbox"/>	<input type="checkbox"/>	<input type="checkbox"/>	Fast recovery rates (eg. 15 minutes for CL125 unit)
<input type="checkbox"/>	<input type="checkbox"/>	<input type="checkbox"/>	CFC/HCFC free (ODP zero) insulation and insulated temperature and pressure relief valve for maximum heat retention
<input type="checkbox"/>	<input type="checkbox"/>	<input type="checkbox"/>	No fear of frozen loft pipes**
<input type="checkbox"/>	<input type="checkbox"/>	<input type="checkbox"/>	No anode to check or replace
<input type="checkbox"/>	<input type="checkbox"/>	<input type="checkbox"/>	Mains fed hygienic hot water
<input type="checkbox"/>	<input type="checkbox"/>	<input type="checkbox"/>	Appliance quality, easy-clean finish
<input type="checkbox"/>	<input type="checkbox"/>	<input type="checkbox"/>	Long-life Duplex stainless steel interior
<input type="checkbox"/>	<input type="checkbox"/>	<input type="checkbox"/>	25-year transferable cylinder guarantee
<input type="checkbox"/>	<input type="checkbox"/>	<input type="checkbox"/>	Patented internal expansion system
<input type="checkbox"/>	<input type="checkbox"/>	<input type="checkbox"/>	Meets BBA Internal Expansion Volume Endurance Test
<input type="checkbox"/>	<input type="checkbox"/>	<input type="checkbox"/>	No external expansion vessel
<input type="checkbox"/>	<input type="checkbox"/>	<input type="checkbox"/>	Complete with mains water isolating valve
<input type="checkbox"/>	<input type="checkbox"/>	<input type="checkbox"/>	Flexibility in cylinder siting**
<input type="checkbox"/>	<input type="checkbox"/>	<input type="checkbox"/>	Dry roof space increases design options***
<input type="checkbox"/>	<input type="checkbox"/>	<input type="checkbox"/>	Cost effective installer friendly connections
<input type="checkbox"/>	<input type="checkbox"/>	<input type="checkbox"/>	No reduction in operating pressure or flow rates
<input type="checkbox"/>	<input type="checkbox"/>	<input type="checkbox"/>	Supplied with safety and hot water controls, wiring centre for indirect models and drain valve
<input type="checkbox"/>	<input type="checkbox"/>	<input type="checkbox"/>	No cold feed cistern to install for the hot water supply
<input type="checkbox"/>	<input type="checkbox"/>	<input type="checkbox"/>	Neater and quicker installation
<input type="checkbox"/>	<input type="checkbox"/>	<input type="checkbox"/>	Easy to commission
<input type="checkbox"/>	<input type="checkbox"/>	<input type="checkbox"/>	No costly shower pump to install
<input type="checkbox"/>	<input type="checkbox"/>	<input type="checkbox"/>	Lightweight, installer friendly design
<input type="checkbox"/>	<input type="checkbox"/>	<input type="checkbox"/>	Stronger construction for durability and high pressure performance
<input type="checkbox"/>	<input type="checkbox"/>	<input type="checkbox"/>	All units fully factory tested to ensure reliability
<input type="checkbox"/>	<input type="checkbox"/>	<input type="checkbox"/>	Fully indemnified design service. Conditions apply

* Energy Efficiency Partnership: Central Heating System Specifications.
 ** Assumes sealed system boiler with Megaflo in frost free position.
 *** Assumes no loft conversion.

Megaflo HE THE INSIDE STORY



Unique internal air gap system

- 1 Internal air gap to accommodate expanded water
- 2 Patented floating baffle maintains the air gap

Stainless steel construction

- 3 22mm compression / 3/4" BSP hot water outlet
- 4 Cylinder manufactured from top grade Duplex stainless steel - specially selected for its high strength and resistance to stress and crevice corrosion
- 5 22mm compression / 3/4" BSP cold water inlet
- 6 Integral feet
- 7 22mm compression / 3/4" BSP primary flow
- 8 22mm compression / 3/4" BSP primary return
- 9 Primary heating coil for use with indirect systems (CL models only)
- 10 Patented cold water diffuser

Appliance-quality finish

- 11 White plastic-coated corrosion proofed outer case with grey moulded top and bottom covers and electrical housings for neat and attractive finish
- 12 Grommets on indirect pipework for professional finish

High performance

- 13 Totally insulated with 100% CFC-free (ODP zero) Polyurethane to minimise heat loss (50mm thick)
- 14 Wide choice of products from 70 litre to 300 litre
- 15 Long-life 3kW Superloy 825 immersion heater

Safety controls

- 16 1/2" Temperature and Pressure Relief Valve with innovative insulation casing, operating at 90°C/10 bar
- 17 Indirect thermal controls (CL models)
- 18 Drain valve
- 19 Wiring centre for indirect controls (indirect Megaflo HE only)

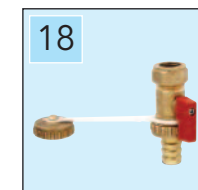
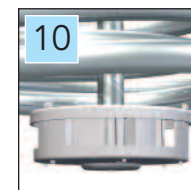

In built quality

Megaflo units are manufactured in the UK in a BS EN ISO 9001:2000 registered factory. All Megaflo units are fully BBA, WRAS and CE approved with full BEAB approval on all electrical components. Copies of certificates are available on request.

Megafllo HE performance

Nominal Capacity litre	Recovery Model CL (Indirect) minutes	Heat up Direct 3kW (Model D) minutes	Heat up Direct 6kW (Model DD) minutes	Heat up Direct 9kW (Model DDD) minutes	Boost Heat top element (DD & DDD) minutes	Heat loss in 24 hrs. kWh
70	10	87	N/A	N/A	N/A	1.10
125	15	137	69	N/A	66	1.49
145	17	153	77	N/A	72	1.65
170	15.5	181	91	N/A	79	1.77
210	19	199	100	67	85	1.97
250	23	238	119	79	92	2.09
300	27	287	144	96	97	2.25

CL are indirect models with one electrical element. CL210HE, CL250HE and CL300HE have additional boost upper element boss blanked off, additional immersion heater available.

Element loading options

Model		Lower	Upper
D	1 x 3kW	1	N/A
DD	2 x 3kW	1	1
DDD	3 x 3kW	2	1
DDD*	3 x 3kW	3	0
DDD*	4 x 3kW	3	1
CL	1 x 3kW	1	N/A
CL*	2 x 3kW	1	1

* With extra element option (CL210HE, CL250HE, CL300HE and DDD models)

Recovery times for CL models with various boiler outputs (based on 70% recovery)

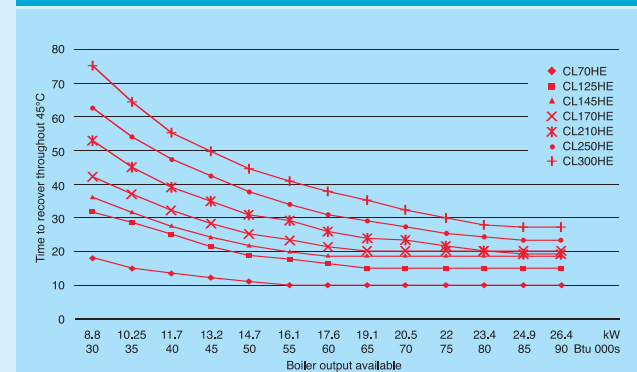

Dimensions

Model	A	B	C	D	E
D70	N/A	308	494	784	N/A
CL70	315	354	494	784	N/A
DD125	N/A	308	793	1089	541
CL125	315	354	793	1089	N/A
DD145	N/A	308	894	1215	642
CL145	315	354	894	1215	N/A
DD170	N/A	308	1019	1372	767
CL170	315	354	1019	1372	N/A
DD210 + DDD210	N/A	308	1095	1473	861
CL210	315	354	1095	1473	861
DD250 + DDD250	N/A	308	1322	1725	1071
CL250	315	354	1322	1725	1071
DD300 + DDD300	N/A	308	1573	2040	1375
CL300	315	354	1573	2040	1375

Megafllo HE

Indirect

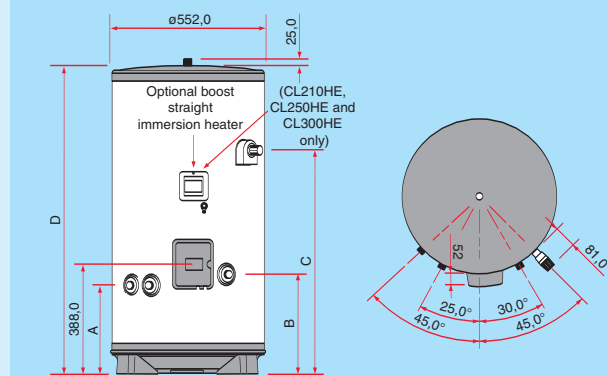

Direct (D, DD)

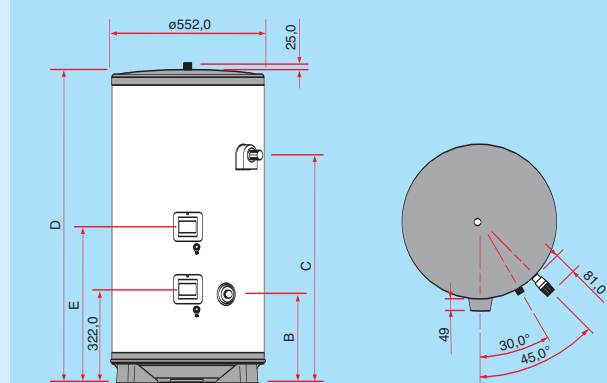

Direct (DDD)

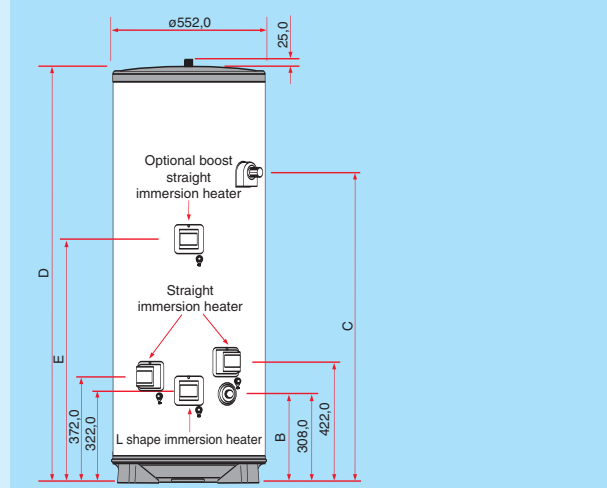

Specification 70/125/145/170/210/250/300

Nominal capacities 70, 125, 145, 170, 210, 250 and 300 litre.

Rating Immersion heater/s 3kW @ 240V. Up to four can be fitted dependent on model.

Outer casing White plastic coated corrosion proofed steel.

Thermal insulation CFC/HCFC-free (ODP zero) flame-retardant expanded polyurethane (50mm thick). GWP 3.1 (Global Warming Potential).

Water container Duplex stainless steel with internal air-gap system.

Pressure testing To 15 bar.

Heat unit Long-life Superloy 825 alloy sheathed element/s, incorporated into an easily removable heater plate, should replacement be necessary. Rated 3.0kW @ 240V.

Primary coil 22mm diameter stainless steel.

Thermostat Direct models: Element thermostat adjustable from 10°C to 70°C. Indirect models: Factory-fitted cylinder thermostat adjustable to 70°C.

Factory fitted safety features Direct models: Manually re-settable cut-out on heating element operates at 85°C. Indirect models: High limit thermal cut-out operates at 85°C. Wired in series with two-port motorised valve (supplied) to provide primary over temperature protection. All models: Temperature and Pressure Relief Valve, factory set to operate at 10 bar and 90°C (insulation casing supplied loose). Wiring centre for indirect controls (supplied loose).

Anode Not required.

Approvals BBA and CE approved. Manufactured in the UK in a BS EN ISO 9001:2000 registered factory.



Installation

Must be installed by a competent installer in accordance with Local Regulations. England and Wales - Building Regulations G3. Scotland - Technical Standards P3. N. Ireland - Building Regulations P5.

Fixing For floor mounting.

Plumbing Inlet/outlet: 3/4" BSP male parallel and 22mm compression fittings supplied. Indirect coil: 3/4" BSP male parallel and 22mm compression fittings supplied. 1/2" T&P Relief Valve: 15mm compression outlet supplied.

Cold water control 22mm HiFlo cold water valve assembly comprising 3 bar pressure reducer, 1/4 turn isolating ball valve, line strainer, non-return valve and expansion valve (8 bar).

Cold water control valve (3 bar) is supplied for use with mains pressure of 16 bar to 1.5 bar, at the lower pressure, performance will be reduced accordingly. Normal working pressure is 3 bar.

Water expansion Via air gap built into the top of the cylinder. The patented floating baffle maintains the air gap.

Flow rates Up to 72 litres per minute (depending on adequate supply conditions).

Minimum water supply requirements 20 litres per minute flow and 1.5 bar pressure. (At lesser values, the unit will operate but outlet flow rates may be unacceptable, especially with multiple draw-offs). Please contact our Specification Advice Team to discuss specific site conditions if the above minimum requirement cannot be met.

Secondary circulation Via 22 x 15 x 22mm swept tee (not supplied, available as accessory 95:970:509).

Fitted to inlet pipework (circulating pump not supplied).

Secondary circulation is not recommended for direct electric units being used on off-peak electricity tariffs.

Compatible boilers Gas, electric or oil fired - sealed system or open vent type, fitted with integral control thermostat and thermal cut-out.

Tundish 15mm inlet and 22mm compression outlet.

Electrical Connection is direct to terminals in the immersion heater which must be permanently connected to the supply through a double-pole linked isolating switch with a minimum breaking capacity of 13A.

On indirect models, controls should be wired to the boiler, programmer etc. in accordance with the control scheme being used. All electrical installations must conform to the latest IEE Wiring Regulations.

Guarantee

The Megafllo HE Duplex stainless steel vessel carries a full 25-year transferable on-site service support guarantee against faulty manufacture or materials provided that:

- It has been correctly installed as per the instructions contained in the instruction manual and all relevant Codes of Practice and Regulations in force at the time of installation.
- It has been installed in the UK.
- It has not been modified in any way, other than by Heatrae Sadia Heating.
- The damage is not due to scaling or frost.
- It has only been used for the storage of potable water.
- It has not been tampered with or been subjected to misuse or neglect.
- Within 60 days of installation the user completes and returns the certificate supplied along with the proof of purchase to register the product.



The Megafllo HE cold water control valve is guaranteed for a period of five years from date of purchase. The immersion heater and thermal controls are guaranteed for a period of two years from the date of purchase. Evidence of purchase and date of supply must be submitted. The unit is not guaranteed against damage due to scaling or frost. The guarantee is transferable. This guarantee does not affect your statutory rights.

Ordering guide

Megafllo	Nominal Capacity litre	Element Rating @ 240V kW	Coil Rating kW	Weight empty kg	Weight full kg	Product code
D70HE	70	1 x 3		23	123	95:050:360
CL70HE	70	1 x 3	15.4	25	125	95:050:361
DD125HE	125	2 x 3		25	174	95:050:362
CL125HE	125	1 x 3	18.3	27	176	95:050:363
DD145HE	145	2 x 3		31	200	95:050:364
CL145HE	145	1 x 3	18.7	35	204	95:050:365
DD170HE	170	2 x 3		34	228	95:050:366
CL170HE	170	1 x 3	24.3	39	233	95:050:367
DD210HE	210	2 x 3		38	248	95:050:368
DDD210HE	210	3 x 3		39	249	95:050:380
CL210HE	210	1 x 3	24.3	43	253	95:050:369
DD250HE	250	2 x 3		45	295	95:050:370
DDD250HE	250	3 x 3		46	296	95:050:371
CL250HE	250	1 x 3	23.9	50	300	95:050:372
DD300HE	300	2 x 3		55	355	95:050:373
DDD300HE	300	3 x 3		56	356	95:050:374
CL300HE	300	1 x 3	24.5	60	360	95:050:375

Accessories ordering guide

	Product code
Megafllo HE immersion heater with thermostat - upper 'straight'	95:970:510
Swept tee (22x15x22)	95:970:509



Megaflo HE SystemFit PRE-PLUMBED UNVENTED WATER HEATING

The ultimate unvented cylinder pre-plumbed solution. The UK's market leading Megaflo HE range is now available in a popular pre-plumbed format – designed to significantly reduce on-site installation time. These factory assembled units are pre-plumbed and pre-wired with 230V central heating controls, pump, two 2-port motorised valves, automatic by-pass and balancing valve, Primary system filling loop, Primary system pressure gauge and Primary system expansion vessel and auto air vent.

This new time-saving Megaflo HE SystemFit package not only speeds installation but significantly enhances the quality and integrity of the central heating system thus eliminating costly call backs.

Features

Megaflo HE - the UK's No.1 unvented cylinder

125, 145, 170, 210, 250 and 300 litre capacities – S-plan

Programmable thermostat with timed Domestic Hot Water (DHW) Control

Separate central heating and hot water zones

No maintenance three speed circulating pump

Automatic by-pass valve for system efficiency

Load balancing valve for indirect coil efficiency

Connections for vented and unvented heating primaries

Primary system filling loop, Primary system pressure gauge and Primary system expansion vessel and auto air vent

Benefits

Simplified on-site installation

Up to 70% quicker to install

Factory assembled for reliability - reduces costly call-backs and delays

Consistent electrical and plumbing layout - neat, professional finish

Greater customer satisfaction

ISO 9001: 2000 quality assured

25-year cylinder guarantee



Megaflo HE SystemFit PRE-PLUMBED UNVENTED WATER HEATING

Separate Central Heating and Hot Water Configuration

- 1 Motorised valve to radiator circuit - 22mm on 125L/145L models / 28mm on other models
- 2 22mm motorised valve to Megaflo coil heat exchanger
- 3 Wiring centre
- 4 Programmable thermostat and room sensor with timed Domestic Hot Water (DHW) Control
- 5 Hot water temperature thermostat

High performance configuration

- 6 Automatic by-pass valve
- 7 3 speed circulator pump with quality isolating valves
- 8 Balancing valve
- 9 22mm cold water combination valve (supplied loose)
- 10 Combined expansion valve/check valve housing
- 11 22mm or 3/4" BSP hot outlet to taps
- 12 22mm Primary flow to Megaflo coil heat exchanger
- 13 22mm Primary return from Megaflo coil heat exchanger
- 14 Immersion heater with integral thermostat and thermal cut-out
- 15 Drain cocks

Comprehensive safety controls

- 16 Temperature and pressure relief valve (with innovative insulation casing supplied loose (16a) operating at 90°C / 10 bar
- 17 Tundish
- 18 High limit hot water thermal cut-out

Connections

- 19 Primary flow connection from boiler - 22mm on 125L/145L models / 28mm on other models
- 20 Discharge pipe connection 22mm
- 21 Cold water inlet connection 22mm
- 22 Primary flow to radiators (CH circuit)
- 23 28mm Connection for 2nd CH zone (supplied capped) 170 litre and above only)
- 24 15mm Connection for secondary return (supplied capped)
- 25 Auto air vent
- 26 Primary system pressure gauge
- 27 Primary system filling loop
- 28 Primary system expansion vessel
- 29 Primary circuit return connection

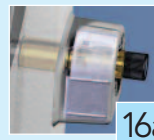
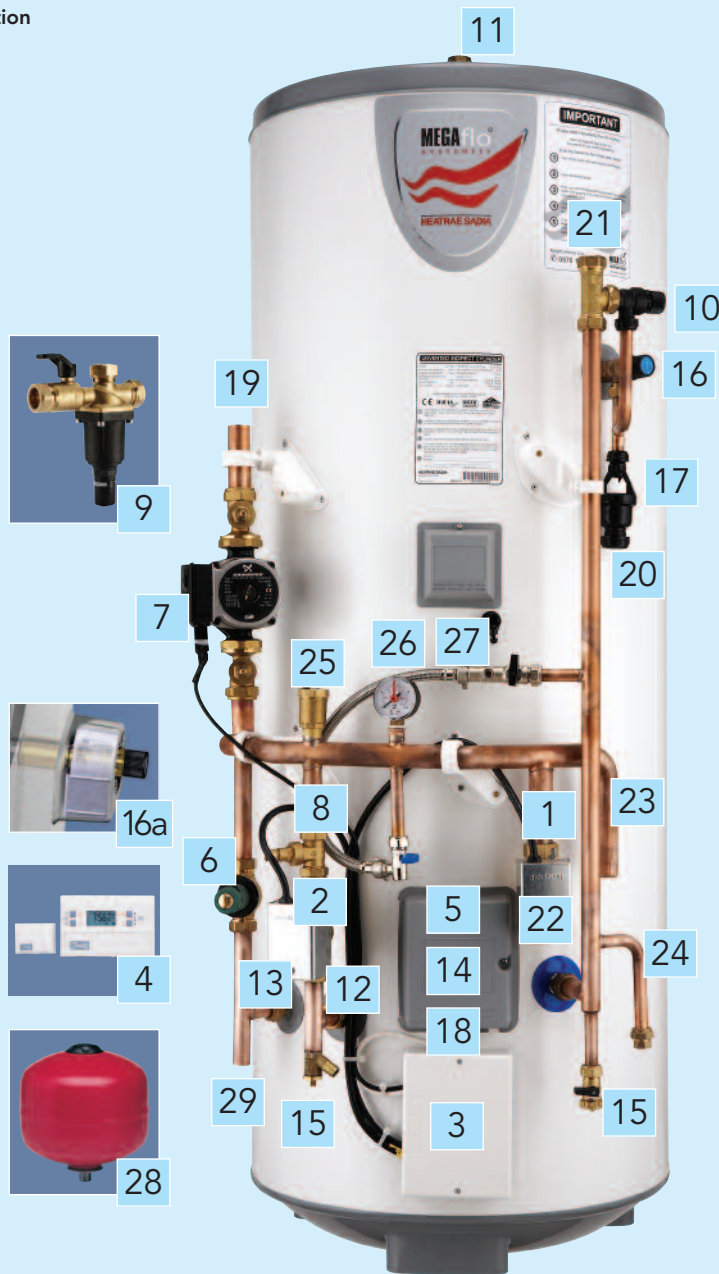

Megaflo HE SystemFit

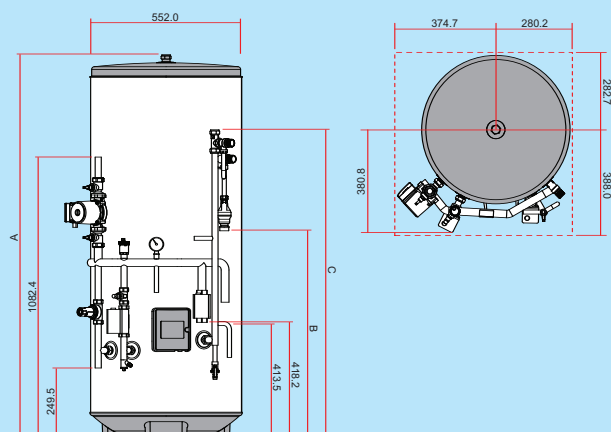

Dimensions

Model	A (mm)	B (mm)	C (mm)
CL125S	1115	542	896
CL145S	1241	643	997
CL170S28	1398	768	1122
CL210S28	1499	844	1198
CL250S28	1751	1071	1425
CL300S28	2065	1322	1676

Specification of cylinder

Nominal capacities 125, 145, 170, 210, 250 and 300 litre.
Rating Immersion heater 3kW @ 240V.
Outer casing White plastic coated corrosion proofed steel.
Thermal insulation CFC/HCFC free (ODP zero) flame-retardant expanded polyurethane (50mm thick). GWP 3.1 (Global Warming Potential).
Water container Duplex stainless steel with internal air-gap system.
Pressure testing To 15 bar.
Heat unit Long-life Superloy 825 alloy sheathed element, incorporated into an easily removable heater plate, should replacement be necessary. Rated 3.0kW @ 240V.
Primary coil 22mm diameter stainless steel.
Thermostat Element thermostat adjustable from 10°C to 70°C. Factory-fitted cylinder thermostat adjustable to 70°C.
Factory fitted safety features Direct: Manually re-settable cut-out on heating element operates at 85°C.
 Indirect: High limit thermal cut-out operates at 85°C.
 Wired in series with two-port motorised valve (supplied fitted) to provide primary over temperature protection.
 All models: Temperature and Pressure Relief Valve, factory set to operate at 10 bar and 90°C (insulation casing supplied loose).
Anode Not required.
Approvals BBA and CE approved cylinder. Manufactured in the UK in a BS EN ISO 9001:2000 registered factory.



Specification of components

Danfoss TP9000 Programmable Room Thermostat with Domestic Hot Water (DHW) Control
Built in hot water time control
Remote room temperature sensor
Chrono-proportional control on/off
Frost protection setting
Easy to use overrides
Up to 6 time/temperature changes per day
7 day, 5/2 or 24 hour operation
Wallplate construction
Room temperature control range 5°C to 30°C
Holiday mode
Programmer dimensions Width 135mm, Height 88mm, Depth 32mm
Sensor dimensions Width 61mm, Height 45mm, Depth 22mm. Designed to meet BS EN60730-2-7 and EN60730-2-9
Maximum ambient temperature 45°C
Timing accuracy ± 1 minute
Switch rating 230Vac, 50/60Hz, 3(1A)
Switching action 2x SPDT, type 1BS
Power supply 230Vas, 50H. Memory back up retained for life of product

Honeywell two-port valve:
 For the central heating and domestic hot water.
Model no V4043H
Voltage rating 230V ac 50Hz
Power consumption 6W
Primary water temperature range 5°C to 88°C
Max ambient temperature 50°C

Automatic by-pass valve:
Model no RWC Diff 391 901
Working pressure 10 bar
Setting range 0.1 to 0.5 bar differential pressure
Maximum primary water temperature 120°C

Pump:
Model no Grundfos UPS15-60
Working pressure 10 bar max
Voltage rating 230V ac 50Hz
Starting capacitor 2µF
Power consumption Speed setting I 40W, Speed setting II 65W, Speed setting III 95W
Enclosure protection IP42

Installation

Must be installed by a competent installer in accordance with Local Regulations. England and Wales - Building Regulations G3. Scotland - Technical Standards P3. N. Ireland - Building Regulations P5.
Fixing For floor mounting.
Plumbing Inlet: 22mm compression. Outlet: 22mm compression / 3/4" BSP male. Primary connections: 22mm O/D Copper on 125/145L models / 28mm OD Copper on other models. 1/2" T&P relief valve 15mm compression outlet supplied fitted.
Cold water control 22mm HiFlo cold water valve assembly comprising 3 bar pressure reducer, 1/4 turn isolating ball valve, line strainer, non-return valve. Expansion core unit comprising 8 bar expansion valve and check valve factory fitted. Cold water control valve (3 bar) is supplied for use with mains pressure of 20 bar to 1.5 bar, at the lower pressure, performance will be reduced accordingly. Normal working pressure is 3 bar.
Water expansion Via air gap built into the top of the cylinder. The patented floating baffle maintains the air gap.
 NOTE: A separate expansion vessel will be required for sealed primary systems.
Flow rates Up to 72 litres per minute (depending on adequate supply conditions).
Minimum water supply requirements 20 litres per minute flow and 1.5 bar pressure. (At lesser values, the unit will operate but outlet flow rates may be unacceptable, especially with multiple draw-offs).
 Please contact our Specification Advice Team to discuss specific site conditions if the above minimum requirement cannot be met.
Secondary circulation Via 15mm tee piece on inlet pipe (supplied capped). A WRAS listed bronze circulating pump (not supplied) will be required.
Compatible boilers Electric, gas or oil fired - sealed system or open vent type, fitted with integral control thermostat and thermal cut-out.
Tundish 15mm inlet and 22mm compression outlet factory fitted.
Electrical Connection is direct to terminals in the immersion heater which must be permanently connected to the supply through a double-pole linked isolating switch with a minimum breaking capacity of 13A.
 Indirect controls should be wired to the boiler, in accordance with the control scheme being used. All electrical installation must conform to the latest IEE Wiring Regulations.
 Heatrae Sadia's Specification Advice Team is available to discuss requirements for specific projects, applications and product selection.

Guarantee

The Megaflo HE Duplex stainless steel vessel carries a full 25-year transferable on-site service support guarantee against faulty manufacture or materials provided that:

- It has been correctly installed as per the instructions contained in the instruction manual and all relevant Codes of Practice and Regulations in force at the time of installation.
- It has not been modified in any way, other than by Heatrae Sadia Heating.
- It has been installed in the United Kingdom.
- It has not been frost damaged.
- It has only been used for the storage of potable water.
- It has not been tampered with or been subjected to misuse or neglect.
- Within 60 days of installation the user completes and returns the certificate supplied along with the proof of purchase to register the product.

The Megaflo HE SystemFit components, immersion heater and thermal controls are guaranteed for a period of 2 years from the date of purchase. 5 years for cold water control valve and SystemFit Primary expansion vessel. Evidence of purchase and date of supply must be submitted. The unit is not guaranteed against damage due to frost. The guarantee is transferable. This guarantee does not affect your statutory rights.



Ordering guide

Megaflo HE SystemFit	Nominal Capacity litre	Element Rating @ 240V kW	Coil Rating kW	Product code
CL125S	125	3.0	18.3	95:050:382
CL145S	145	3.0	18.7	95:050:384
CL170S28	170	3.0	24.3	95:050:393
CL210S28	210	3.0	24.3	95:050:394
CL250S28	250	3.0	23.9	95:050:395
CL300S28	300	3.0	24.5	95:050:396
Optional boost element available for CL210 to CL300 units.				
For an extra element, order code number				95:970:510

HEATRAE SADIA

The quality name in water heating

Products

Boiling water Supreme | Supreme SS

Chilled water SuperChill

Cistern-fed water heating Megalife HE | Megalife Solar

Cistern-type water heating FBM

Electric space heating Amptec | Electromax | Aerheat

Electric showers Accolade | Carousel | Sapphire | Cameo

Hand hygiene Handy | Concept | Hair Drier | Handy Dri

Immersion heaters Titanium | Superloy | Gold Dot | Maxistore | RDT Thermostats

Point of use Streamline | Express | UTC 99 | B3M | C3M | Vented tap range

Small unvented water heating Hotflo | Multipoint

Unvented water heating Megaflo HE | Megaflo HE SystemFit | Megatech Solar

For free product brochure(s) call our literature hotline on 01603 420127

Contact

Specification T: 01603 420220 F: 01603 420229 E: specifier@heatraesadia.com

After Sales Service

T: 0844 8711 535 F: 0844 8711 528 E: heatraesadiaservice@heateam.co.uk

Web www.heatraesadia.com

National service network

Heatrae Sadia products are inherently reliable and are designed to meet the demanding needs of all users.

A nationwide network of experienced engineers is available to provide fast and efficient on-site service support.

In addition, spare parts for the complete range of products are readily available through a wide variety of stockists.



Heatrae Sadia Heating Hurricane Way Norwich Norfolk NR6 6EA

Heatrae Sadia Heating may introduce modifications to their products from time to time. Consequently, the details given in this brochure are subject to alteration without notice.

95 900 807 Issue HE11 © Heatrae Sadia Heating. September 2008.

A division of BAXI GROUP